



SABIANA
IL CLIMA AMICO

A leading brand of  AFG



FSE

Electric Fan Convectors

The **FSE** electric fan convectors are made in 5 sizes, with heat outputs **from 3 to 8,5 kW**.

The electric coil has two-stage sealed electrical resistance made of finned steel tubes to allow two step operation. The power supply is three phase, 400 V - 50 Hz. The first two sizes (**up to 4,5 kW**) can also be supplied in the single-phase version.

As standard they are fitted with two speed control, room thermostat and switch for electric heater two step operation.

Technical characteristics of the main components:

Version: three-phase 400 V~ (3p + N) or single-phase 230 V~.
Only for vertical installation.

Casing: in hot dip galvanised and pre-painted steel;
it is easily removed for complete access to the unit.
The air outlet grill, located on the upper part of the unit, **is reversible.**

Fan assembly: made of ultra-silent double intake **centrifugal fans**
with statically and dynamically balanced aluminium impellers
keyed directly onto the motor shaft.

Electric motor: the motor has three speeds with capacitor,
and is fitted on sealed for life bearings and is secured on anti-vibration
and self-lubricating mountings. Protection IP 20, class B.

Coil: protected electrical resistances with firmed steel pipe.
The power is divided into two stages
in order to allow it to operate **at partialized load.**

Electrical panel: includes all control and protection automations,
auxiliary and safety circuits and the terminal board, ready for connections to the supply line.

Control: built-in control
with ON-OFF switch, speed switch and room thermostat.

Dimensions, Weight and Technical data

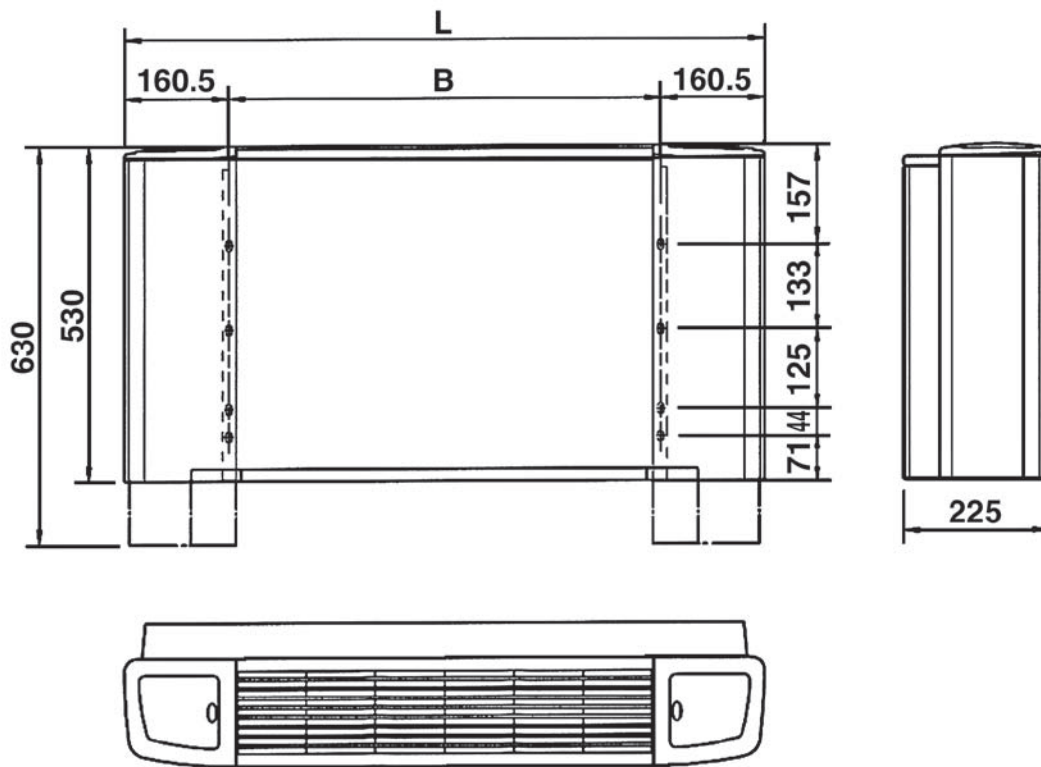

MODEL	DIMENSIONS (mm)		WEIGHT WITH PACKAGING
	B	L	kg
FSE 1	454	775	27
FSE 2	669	990	31
FSE 3	884	1205	39
FSE 4	1099	1420	45
FSE 5	1099	1420	45

MODEL	230 U~			400 U~ (3p+N)																				
	FSE 1			FSE 2			FSE 1			FSE 2			FSE 3			FSE 4			FSE 5					
Speed	1	2	3	1	2	3	1	2	3	1	2	3	1	2	3	1	2	3	1	2	3			
Air flow	m³/h			190	240	300	290	360	450	190	240	300	290	360	450	380	480	600	650	800	1000	650	800	1000
Heat output	kW			-	1,90	3,00	-	2,90	4,50	-	1,90	3,00	-	2,90	4,50	-	4,00	6,00	-	5,00	7,50	-	5,60	8,50
Motor output	W			20	30	50	45	50	60	20	30	50	45	50	60	60	80	95	65	85	125	65	85	125
Absorbed power (*)	ampère			13,5			20,0			5,0			7,0			9,5			10,0			13,0		
Sound power	Lw	dB(A)		40	45	50	42	47	52	40	45	50	42	47	52	35	42	51	48	56	59	48	56	59
Sound pressure (**)	Lp	dB(A)		31	36	41	33	38	43	31	36	41	33	38	43	26	33	42	39	47	50	39	47	50

(*) = Figures at high power and high speed.

(**) = The sound pressure levels are 9 dB(A) lower than the sound power levels and apply to the reverberant field of a 100 m³ room and a reverberation time of 0.5 sec.

Accessories

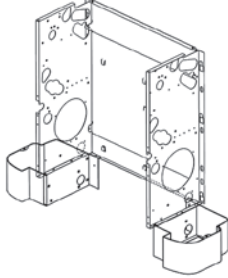
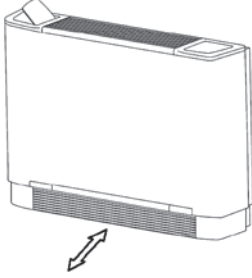
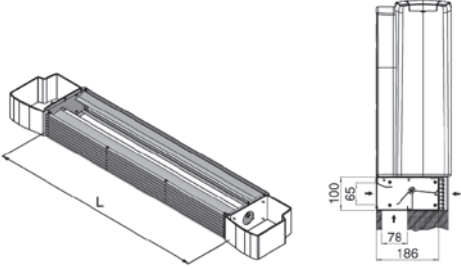
PAP	Feet	
GAP	Aluminium intake grid To be installed with PAP feet.	
SAE	Damper for fresh air intake <i>(not motorizable)</i>	

Mounted fitted control

<ul style="list-style-type: none">- ON-OFF switch.- Manual 3 speed switch:<ul style="list-style-type: none">• Fan only at low speed.• Low heating power at medium speed.• High heating power at high speed.- Simultaneous thermostatic control of the electric heater and fan. <p>The unit is equipped with a manually reset safety thermostat that stops power to the electrical coil.</p>	
--	--

The descriptions and illustrations provided in this publication are not binding: Sabiana reserves the right, whilst maintaining the essential characteristics of the types described and illustrated, to make, at any time, without the requirement to promptly update this piece of literature, any changes that it considers useful for the purpose of improvement or for any other manufacturing or commercial requirements.



SABIANA
IL CLIMA AMICO

A leading brand of  **AFG**

Sabiana s.p.a. • via Piaue, 53 • 20011 Corbetta • Milano • Italy

phone +39.02.97203.1 r.a. / +39.02.97270429 / +39.02.97270576

fax +39.02.9777282 / +39.02.9772820

www.sabiana.it • info@sabiana.it